

HC 10 S

VERSIONE POMPA A MANO
HAND PUMP VERSION



 **MAX**
500 KG

I MIGLIORI PRODOTTI DI QUALITÀ | BEST QUALITY PRODUCTS

www.hcindustrie.com

HC 10 S	A1	A2	A3*
MOMENTO DI SOLLEVAMENTO LIFTING MOMENT - MOMENT DE LEVAGE - MOMENTO DE ELEVACIÓN	5 kNm	5 kNm	5 kNm
MASSIMO CARICO SOLLEVABILE MAX. LIFTING CAPACITY - PUISSANCE DE LEVAGE - CARGA ÚTIL MÁXIMA	300 kg	220 kg	110 kg
MASSIMO SBRACCIO IDRAULICO MAX. HYDRAULIC OUTREACH - PORTÉE HYDRAULIQUE MAXIMALE - ALCANCE HIDRÁULICO MÁXIMO	m 1,78	m 2,54	m 3,40
ANGOLO MASSIMO DI ROTAZIONE SLEWING ANGLE - ANGLE DE ROTATION - GIRO MÁXIMO	340°	340°	340°
COPPIA DI ROTAZIONE SLEWING TORQUE - COUPLE DE ROTATION - PAR DE GIRO	kNm 1,9 (0,19 tm)	kNm 1,9 (0,19 tm)	kNm 1,9 (0,19 tm)
PRESSIONE MASSIMA DI LAVORO OPERATING PRESSURE - PRESSION D'UTILISATION - PRESIÓN DE SERVICIO	Mpa 19,0 (190 bar)	Mpa 19,0 (190 bar)	Mpa 19,0 (190 bar)
PORTATA D'OLIO CONSIGLIATA RECOMMENDED PUMP CAPACITY - DÉBIT DE POMPE RECOMMANDÉ - CAUDAL DE ACEITE RECOMENDADO	4-6 l/min.	4-6 l/min.	4-6 l/min.
MASSA DELLA GRU STANDARD ** STANDARD CRANE MASS - MASSE DE LA GRUE STANDARD - PESO DE LA GRUA STANDARD	86 kg	93 kg	96 kg

* **PROLUNGA MANUALE** - MANUAL EXTENSION

** **PESO MACCHINA SENZA COMANDI** - MACHINE WEIGHT WITHOUT CONTROLS

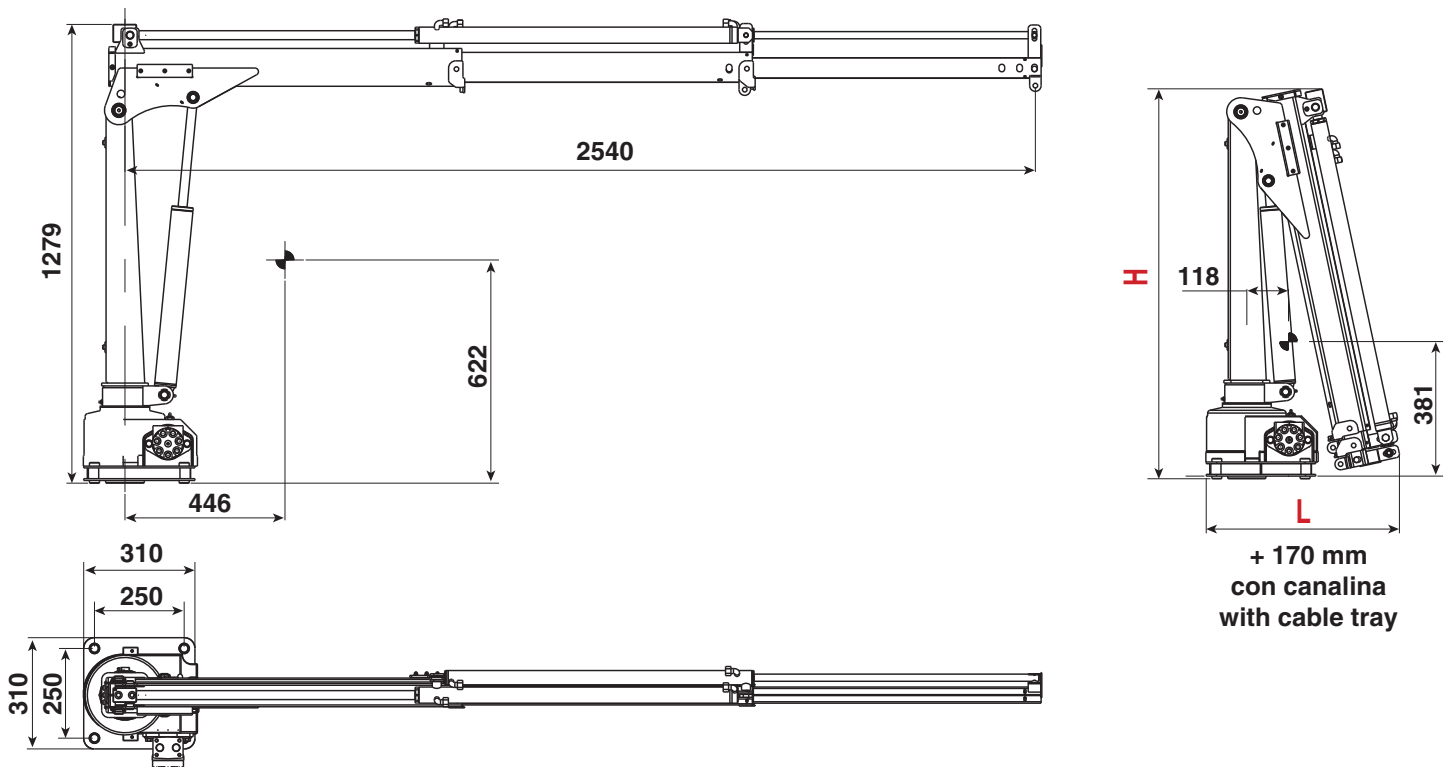

	HC 10 S A1	HC 10 S A2	HC 10 S A3*
L	547 mm	547 mm	547 mm
H	1104 mm	1104 mm	1104 mm

HC 10 S A1

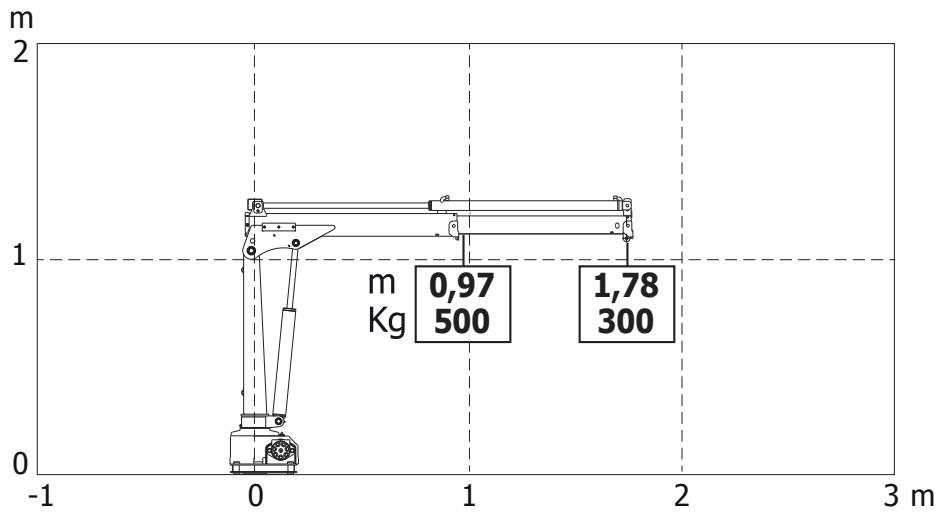

HC 10 S A2

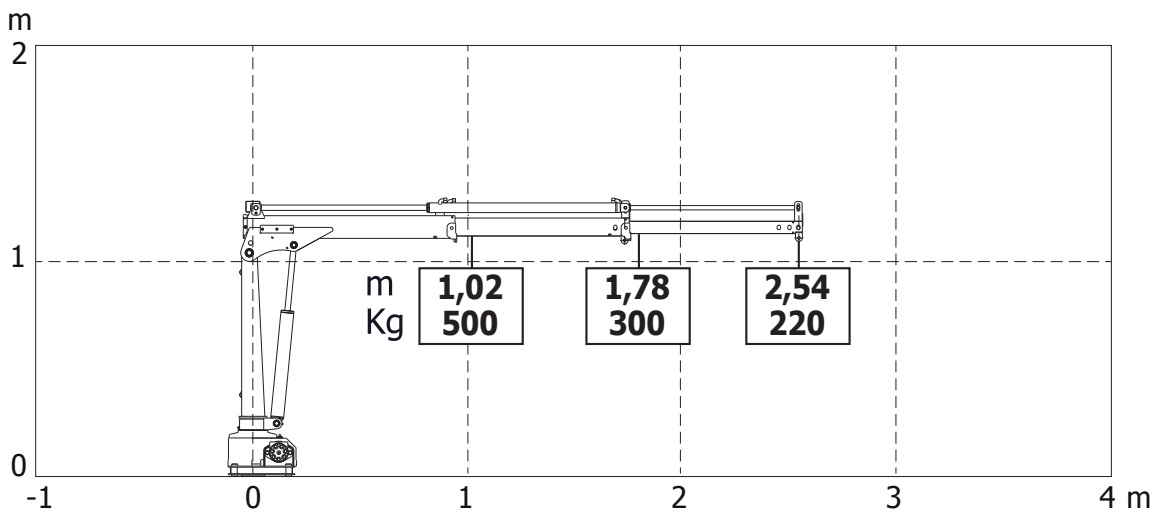

HC 10 S A3*

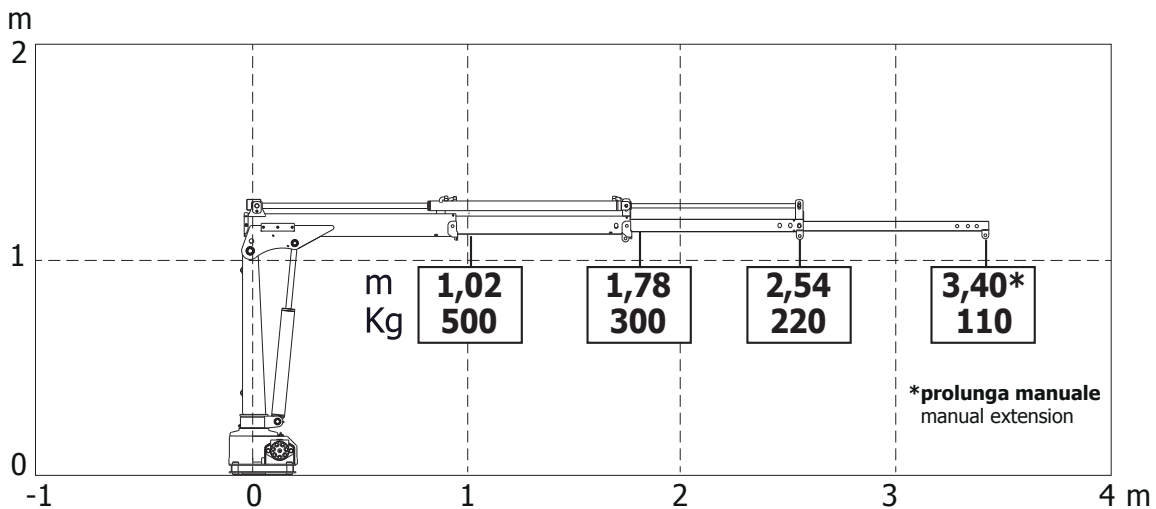

OPTIONAL

BASAMENTO CON STABILIZZATORI - BASEMENT WITH STABILIZERS - CADRE D'ASSEMBLAGE AVEC STABILISATEURS - PLACA DE APOYO CON ESTABILIZADORES

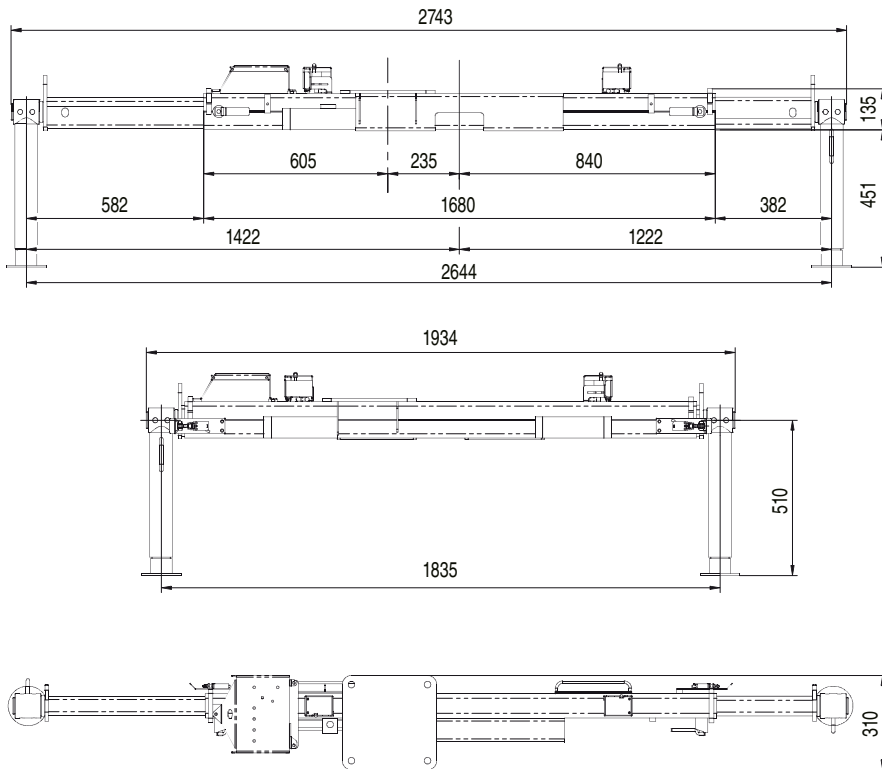

VERSIONE CON CILINDRI STABILIZZATORI MANUALI

VERSION WITH MANUAL STABILIZING CYLINDERS

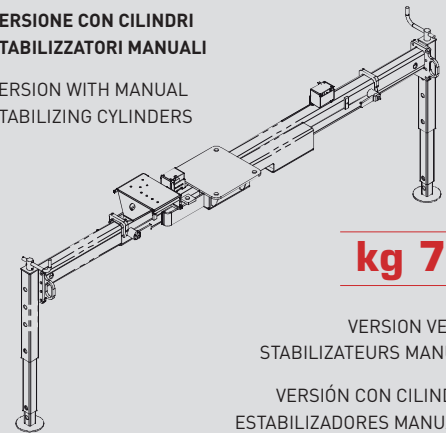

kg 79

VERSION VERINS STABILISATEURS MANUELS

VERSIÓN CON CILINDROS ESTABILIZADORES MANUALES

VERSIONE CON CILINDRI STABILIZZATORI IDRAULICI GIREVOLI

VERSION WITH HYDRAULIC ROTATING STABILIZING CYLINDERS

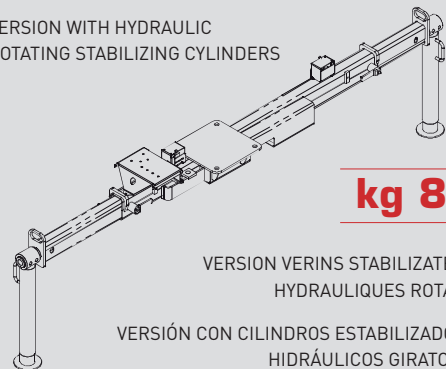

kg 85

VERSION VERINS STABILISATEURS HYDRAULIQUES ROTATIFS

VERSIÓN CON CILINDROS ESTABILIZADORES HIDRÁULICOS GIRATORIOS



TUTTI I DATI TECNICI POSSONO ESSERE CAMBIATI SENZA PREAVVISO - ALL TECHNICAL DATA CAN BE CHANGED WITHOUT NOTICE
TOUS LES DONNEES TECHNIQUES PEUVENT ETRE MODIFIEES SANS PREAVIS - TODOS LOS DATOS TECNICOS PUEDEN SER CAMBIADOS SIN AVISO

HC INDUSTRIE S.R.L.
Via Luciano Romagnoli, 1
42023 Cadelbosco di Sopra Reggio Emilia, Z.I. La Madonnina (RE)
Phone +39.0522.911729 - Fax +39.0522.404040
Email: commerciale@hcindustrie.com - Website: www.hcindustrie.com